

FF DRAWER MAGNETS

W T C F **P** R Q

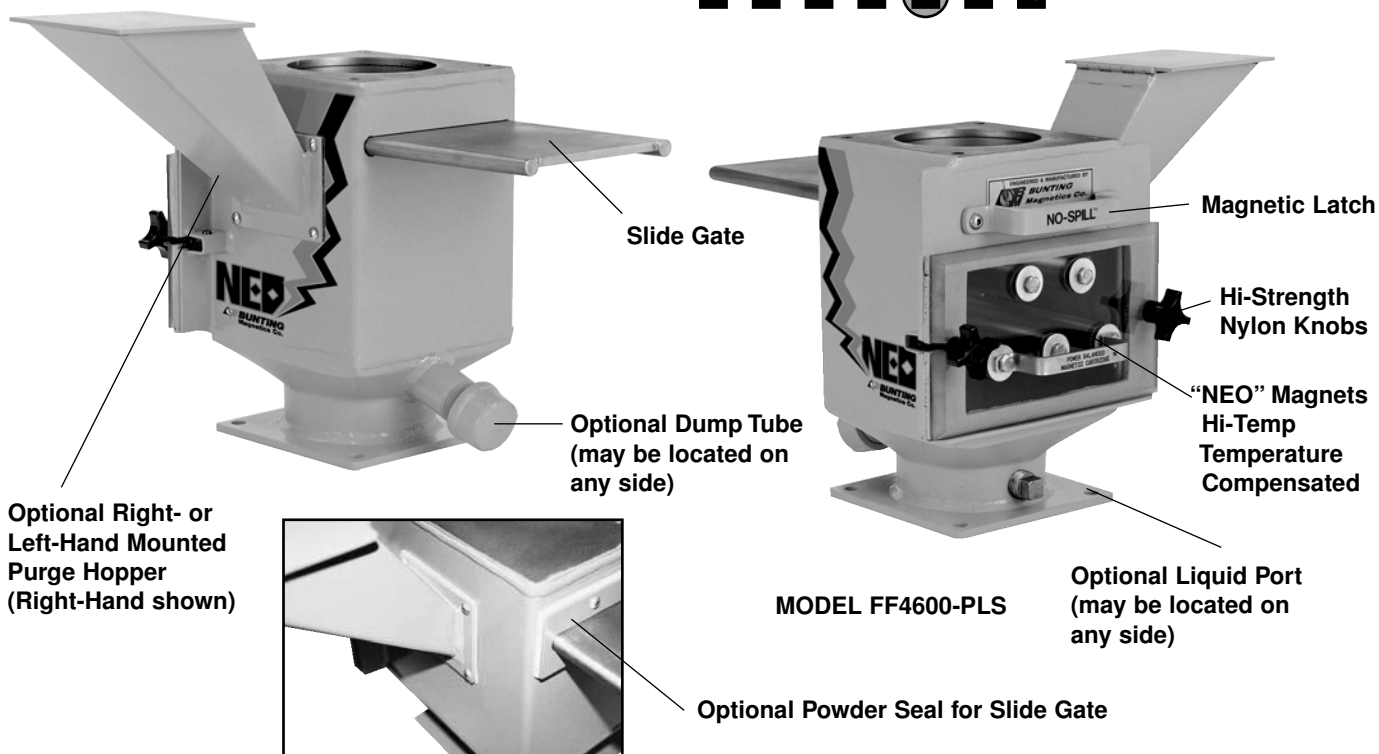

Drawer Magnet Options

Patented No-Spill™ Slide Gate

The patented No-Spill Slide Gate completely and positively shuts off product flow, so you don't have to worry about product spillage creating a mess or safety hazard when you remove the drawer for cleaning.

Purge Hopper

Our Purge Hopper speeds clean-out of your equipment when changing color or compound – without sacrificing magnetic protection or taking the time to empty your hopper.

Dump Tube

This option lets you empty the drawer housing and material hopper of plastic after a run has been completed.

Liquid Port

The Liquid Port allows you to inject liquid color additive into the resin. The port can also be used to hold a temperature probe.

Powder Seal Kit

This option prevents powder materials from leaking out around the Slide Gate – which is especially important in applications involving PVC or similar powder materials. The kit provides a compression seal around the Slide Gate. Order as original equipment or retrofit on site.

“NEO” Magnets

Equipped with the most powerful Rare Earth magnets available in separation equipment. Featuring *the only temperature-compensated, Rare Earth magnets* for injection molding machines.

Stainless Steel Housing

Built with a welded stainless steel housing for easy cleaning and durability.

EPDM Gasket

Featuring a new EPDM gasket that resists heat aging and compression set.

Hi-Strength Nylon Knobs

Fitted with high-torque nylon knobs that resist breakage.

Lexan® Drawer Front

Designed with a clear Lexan drawer front for easy viewing of product flow and captured contaminants.

Magnetic Latch

Exclusive magnetic latch locks the No-Spill Slide Gate open during operation, yet permits easy closing for purging and color changes.

FF DRAWER MAGNETS



Drawer Magnet Selection Guide for Standard and Self-Cleaning FF Series

(Dimensions are in inches and keyed to drawings)



MODEL FF4400-PLS
4x4



MODEL FF4600-PLS
6x6



MODEL FF4800-PLS
8x8



MODEL FF4100-PLS
10x10

Model	FF4400PL/PLS	FF4600PL/PLS	FF4800PL/PLS	FF4100PL/PLS*
A	10½	10¾	10¾	Varies
B	4 X 4	6 X 6	8 X 8	10 X 10
C	6½	8½	10½	12½
D	2¾	4¾	6¾	Varies
E	2¾	2¾	3	Varies
F Min. Rnd. Opp.	7/8	1¾	3½	Varies
G Max. Rnd. Opp.	2½	3¾	6	Varies
H Max. Sq. Opp.	1½	2¾	4¼	Varies
I	1½	1½	1½	Varies
J	¾	¾	¾	Varies
K Max. Opp.	3	5	6¾	8¾
L1 L2 L3	Per Customer Specifications			
M	6¾	6½	6¾	Varies

*Model FF4100PL/PLS is available with welded transition only (no casting).

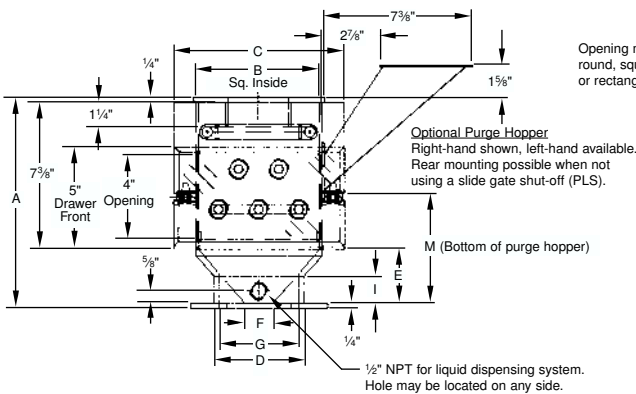

Easy Installation

Each of the four standard FF Series units is available with the original No-Spill™ Slide Gate – Bunting designed and patented – to provide safer and more convenient cleaning. All models are also available with self-cleaning drawer modules. Flanges are pre-drilled to OEM or customer specifications. Be sure to request the options, flange specifications, and hole locations you want when ordering.

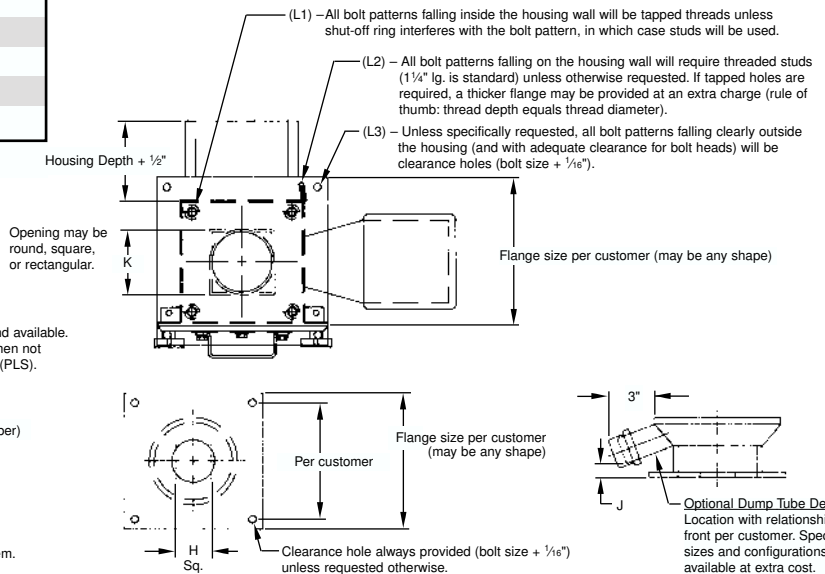

Ordering Information

Bunting part numbers denote models and features. Drawer Magnet Part Numbers have three parts. The initial two letters designate the model type. The numerical digits indicate the size of the square top plate. The trailing letters specify Drawer Magnet options.

For example: **Part FFS4600-PLS-CR**
This part number describes an FF Series Drawer Magnet with a 6" Square Stainless Steel Housing equipped with a Slide Gate and Ceramic Magnet-Powered Cartridges.

FF Series Part Number Explanation

Model/Type	Size	Options
FF = Mild Steel Housing	4400 = 4" Square	PL = Without Slide Gate
FFS = Stainless Steel Housing	4600 = 6" Square	PLS = With Slide Gate
	4800 = 8" Square	
	4100 = 10" Square	

Low-Profile Part Number Explanation

Model/Type	Size	Options
LP = Mild Steel Housing	1600 = 6" Square	PL = Without Slide Gate
LPS = Stainless Steel Housing	1800 = 8" Square	PLS = With Slide Gate

Please specify purge hopper, dump tube, and liquid dispensing port options and locations when ordering.

Our new NEO Drawer Magnets are outfitted with super-strong Neodymium Rare Earth magnets that capture and hold ferrous metal particles so small that you may not be able to see them with the naked eye. Unlike competing Rare Earth drawer magnets that can permanently lose their magnetic fields at temperatures above 175° F, Bunting's exclusive design is the **only** temperature-compensated Rare Earth drawer magnet made for injection molding machines. It is guaranteed not to lose its permanent magnetic strength when bolted to feed throats operating at temperatures in excess of 175° F. That means less downtime for you with reduced screw wear and fewer plugged nozzles.

LOW-PROFILE DRAWER MAGNETS

W T C F **P** R Q



When headroom is critical, you need Bunting's Low-Profile Drawer Magnet. Get Bunting's proven design in a space-saving 5 11/16" overall height. Standard features include a single row of our exclusive Permanent Magnetic Cartridges, clear polycarbonate drawer front, and rigid 10-gauge mild steel construction. You can even purchase these units with our original No-Spill™ Slide Gate option. Stainless steel construction and Rare Earth Magnetic Cartridges are also available. We'll pre-drill the unit's rugged 1/4" thick flanges to your specifications at no extra charge.

Low-Profile Drawer Magnet Selection Guide

Model	LP1600PL	LP1600PLS	LP1800PL	LP1800PLS
A	5 11/16"	7 1/4"	5 15/16"	7 1/2"
B	6 X 6	6 X 6	8 X 8	8 X 8
C	8 1/2"	8 1/2"	10 1/2"	10 1/2"
D	4 3/8"	4 3/8"	6 3/8"	6 3/8"
E	2 3/4"	2 3/4"	3"	3"
F	1 3/4"	1 3/4"	3 1/8"	3 1/8"
Min. Rnd. Opp.				
G	3 7/8"	3 7/8"	6"	6"
Max. Rnd. Opp.				
H	2 3/4"	2 3/4"	4 1/4"	4 1/4"
Max. Sq. Opp.				
I	1 5/16"	1 5/16"	1 11/32"	1 11/32"
J	7/16"	7/16"	3/4"	3/4"
K	5"	5"	6 3/4"	6 3/4"
Max. Opp.				
L1 L2 L3	Per Customer Specifications			
M	2 7/16"	4"	2 7/16"	4"

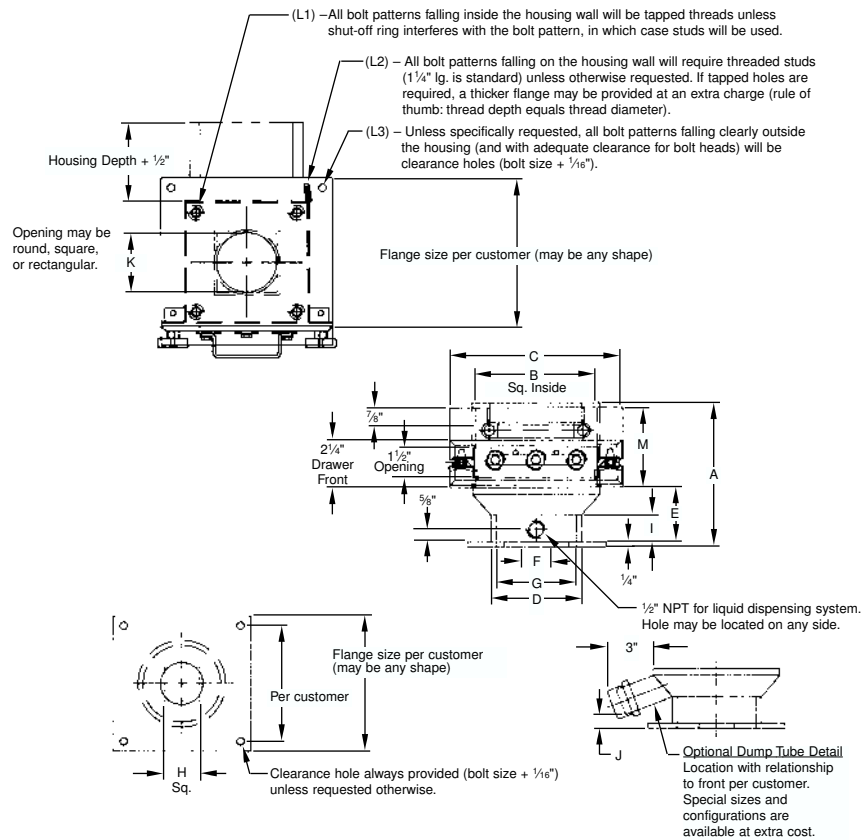

FFV DRAWER MAGNETS

W T C F **P** R Q

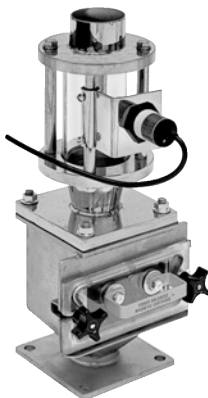

Our FFV Series Drawer Magnets are specifically designed for small volume, closed-loop "Just-In-Time" systems.

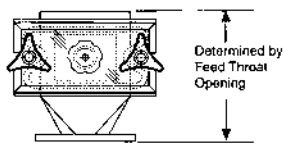

Model
FFSV1300-PL-NPB

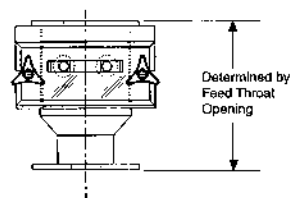
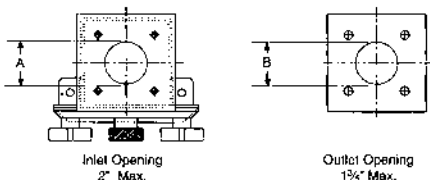

Model
FFV1400-PL-CR
FFSV1400-PL-CR
FFSV1400-PL-NPB

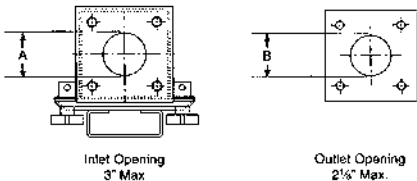

Dimensions A and B per Customer Specs.

TORPEDO MAGNETS

W T C F **P** R Q



Torpedo Magnets are designed to be used in Just-In-Time (JIT) hopper loaders and are the best alternative to drawer magnets available.

The Torpedo Magnet consists of a formed stainless steel ring, welded to a high-energy Rare Earth Magnetic Cartridge. The Magnet hangs suspended in the center of the JIT loader's glass tube. So tramp metal is captured before it can reach your plastic molding machine.

The bottom of the Torpedo Magnet is a live magnetic pole that allows tramp metal to collect and hide, preventing wipe-off back into the product stream.

Torpedo Magnets are available in either 1" or 5/8" diameter designs. We stock four sizes to fit most Just-In-Time loaders.

Part Number	A	B (Approx.)	C	D (Approx.)	F
21-00079	2 1/2	1 7/8	5/8	1 7/8	4 3/4
21-00080	2 1/2	2	1	1 7/8	6 1/4
21-00032	1 3/4	1 5/8	5/8	1 7/8	4 3/4
21-00034	1 3/4	1 5/8	1	1 7/8	6 1/4

Dimensions are in inches. Specifications are subject to change without notice.

